

SYE101B

COMBI FOR CATERING AND LARGE BUSINESSES - 10 X 1/1 GN - ELECTRIC WITH DIRECT STEAM - STEAM GENERATOR OPTIONAL • TOUCH SCREEN CONTROLS - AUTOMATIC INTERACTIVE COOKING

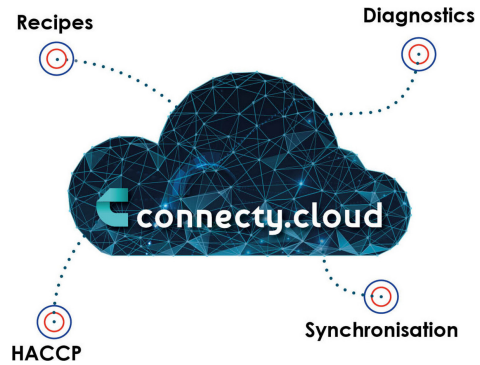

CONNECTY.CLOUD
The completely free platform always at your service.

Features of SYNAPSY



Connecty.cloud
The completely free platform always at your service



Reheating
Fast and consistently excellent service



Automatic Cooking
95 tested recipes available at all times



Smoking
New flavour for your dishes



Multicooking
Perfectly organised service



Ecospeed
The Ecospeed Dynamic system optimises and regulates the power supply according to the quantity and type of product.



Favourites
Your recipes with a click



GreenVapor
The GreenVapor system ensures a net reduction in water and power consumption.



Clima Smart
The ideal Climate for every product

SYE101B

General Data

Capacity	GN	10 x 1/1 GN	Packing dimensions (W x D x H)	mm	990 x 940 x 1260
Distance between layers	mm	70	Weight - Net / Gross	kg	117 / 142
Meals - Croissants	n°	80 / 150 - 90 / 150	Weight - Net / Gross (with steam generator)	kg	127 / 153,7
Max. tray load	kg	15	Volume	m ³	0,8
Max. total load	kg	50	Minimum installation clearance - left side	mm	50
Net external dimensions (W x D x H)	mm	852 x 795 x 1055	Minimum installation clearance - rear side	mm	50
Maximum external dimensions (W x D x H)	mm	852 x 848 x 1102	Minimum installation clearance - right side	mm	500

Power supply

Total electric power	KW	16	Power supply voltage	V	3N-AC 400 V - 50/60 Hz
Total electric power	KW / kcal	15 / -	Frequency	Hz	50/60
Steam heating output_x000D_ (with steam generator)	KW / kcal	15 / -	Differential switch, single-phase frequency converter		RCD cl. B
Consumption	Amp	24			

Water Connection

Cold water inlet	Ø - inch.	3/4	Discharge	kW / kcal	50
Softened water inlet	Ø - inch.	3/4	Minimum water flow	bar	10
Min. pressure	bar	2	Drainage slope		4°
Max. pressure	bar	5			

Water quality

Water hardness for steam generation connection	°dh / ppm	6° / 9° fH	NH ₂ Cl (monochloramine)	mg / l	0,2
pH value	Ph	> 7,5	Max. cold water temperature	°C	30
Cl (chloride) - max	mg / l	30 mg/l max	Max. softened water temperature	°C	50
Cl ₂ (free chlorine)	mg / l	0,1 mg/l max	Electrical conductivity	µs	50 - 200
Fe (iron)	mg / l	0,1 mg/l max			

Emissions

Latent heat	W / kW	1920	Max. liquid discharge temperature	°C	85
Sensitive heat	W / kW	2880	Noisiness	db	< 50

Special voltages and frequencies on request

TS-NAE101B-C60	3-AC 400 V - 60 HZ
TS-NAE101B-B60	3-AC 230 V - 60 HZ
TS-NAE101B-C50	3-AC 400 V - 50 HZ
TS-NAE101B-B50	3-AC 230 V - 50 HZ

COOKING MODES

- AC (AUTOMATIC COOKING) SYSTEM FOR ITALIAN AND INTERNATIONAL RECIPES, AN AUTOMATIC COOKING PROGRAM WITH A PHOTOGRAPHIC REPRESENTATION OF THE DISH.
- AT SMOKER (OPTIONAL), WITH EXTERNAL SMOKER.
- CLIMA SMART - SYSTEM THAT AUTOMATICALLY MANAGES THE PERFECT CLIMATE IN THE COOKING CHAMBER.
- MULTICOOKING MODE - POSSIBILITY TO COOK DIFFERENT FOODS SIMULTANEOUSLY WITH DIFFERENT COOKING TIMES.
- MANUAL MODE WITH THREE COOKING MODES AND INSTANT START: CONVECTION FROM 30°C TO 270°C, STEAM FROM 30°C TO 130°C, COMBINATION CONVECTION + STEAM FROM 30°C TO 270°C.
- PREHEATING UP TO 300°C.

CONNECTIVITY TO CONNECTY.CLOUD - WI-FI OR ETHERNET

- ACCESS TO CONNECTY.CLOUD IS GUARANTEED BY THE CLOUD CONNECTION.
- RECIPE CREATION WITH ILLUSTRATIVE PHOTO.
- DIRECT ACCESS TO RECIPE DATABASE.
- SYNCHRONISATION OF OVENS CONNECTED TO THE SAME ACCOUNT.
- CONTINUOUS HACCP MONITORING EVEN BY REMOTE THROUGH THE CONNECTY.CLOUD PORTAL.
- REMOTE DIAGNOSTICS VIA THE CONNECTY.CLOUD PORTAL.

CONTROL MECHANISMS

- MULTIPOINT CORE PROBE FIXED, Ø 3 MM.
- USER PROFILE BLOCK (SPECIFIC FUNCTION FOR QUICK SERVICE RESTAURANT - QSR).
- REMINDER TO CLEAN AIR FILTERS.
- EXTERNAL WATER-SOFTENER'S EFFICIENCY MONITORING SYSTEM (WATER-SOFTENER OPTIONAL).
- LOW CONSUMPTION LED COOKING CHAMBER LIGHTING. OPTIMAL VISIBILITY IN ALL POINTS OF THE COOKING CHAMBER. NEUTRAL LIGHT THAT DOESN'T ALTER THE ORIGINAL COLOURS OF THE PRODUCT.
- SELF-DIAGNOSIS BEFORE STARTING TO USE THE EQUIPMENT, WITH DESCRIPTIVE AND AUDIBLE SIGNALLING OF ANY ANOMALIES.
- SERVICE PROGRAM: TESTING THE OPERATION OF THE ELECTRONIC BOARD - DISPLAY OF THE TEMPERATURE PROBES - COUNTER FOR OPERATING HOURS OF ALL PRIMARY FUNCTIONS FOR PROGRAMMED MAINTENANCE.
- PRE-CONFIGURED SN ENERGY OPTIMISATION SYSTEM (OPTIONAL).
- POSSIBILITY OF SETTING COMBI SWITCH-OFF AT THE END OF THE AUTOMATIC WASH PROGRAM.
- USB CONNECTION TO DOWNLOAD HACCP DATA, UPDATE SOFTWARE AND LOAD/DOWNLOAD COOKING PROGRAMMES.
- TEMPERATURE CONTROL AT THE PRODUCT CORE USING PROBE WITH 4 DETECTION POINTS.
- ABILITY TO CHOOSE UP TO 6 FAN SPEEDS; THE FIRST 3 SPEEDS AUTOMATICALLY TRIGGER A REDUCTION IN HEATING POWER. FOR SPECIAL COOKING METHODS, YOU CAN USE AN INTERMITTENT SPEED.
- EASY ACCESS TO PROGRAMMABLE USER PARAMETERS TO CUSTOMISE THE APPLIANCE THROUGH THE USER MENU.
- AUTOMATICALLY REGULATED STEAM CONDENSATION.
- AUTO REVERSE (AUTOMATIC REVERSE OF FAN ROTATION) FOR PERFECT COOKING UNIFORMITY.
- PARALLEL CONTROL OF CHAMBER AND CORE TEMPERATURE.
- ECOSPEED DYNAMIC. THE ECOSPEED DYNAMIC SYSTEM OPTIMISES AND REGULATES THE POWER SUPPLY ACCORDING TO THE QUANTITY AND TYPE OF PRODUCT BY CONTROLLING THE CORRECT COOKING TEMPERATURE AND AVOIDING FLUCTUATIONS, THUS REDUCING POWER AND WATER CONSUMPTION, AND EVEN WEIGHT LOSS.
- GREENVAPOR. THE GREENVAPOR SYSTEM ENSURES A NET REDUCTION IN WATER AND POWER CONSUMPTION THANKS TO THE AUTOMATIC CONTROL OF STEAM SATURATION IN THE COOKING CHAMBER.

CONSTRUCTION

- PUSH-TO-CLOSE DOOR AND HANDLE WITH RIGHT OR LEFT OPENING.
- FORCED VENTILATION ELECTRONICS COOLING SYSTEM WITH STAINLESS STEEL MICRO-EXPANDED MESH PROTECTIVE FILTER, EASY TO REMOVE AND DISHWASHER SAFE.
- SOLID STATE RELAY FOR POWER OPTIMISATION AND MODULATION.
- COMPACT BRUSHLESS MAGNETIC DRIVE MOTORS.
- BUILT-IN DOOR DRIP TRAY COLLECTING THE CONDENSATE INTO THE OVEN DRIP TRAY; THEN INTO THE OVEN DRAIN.
- NEW PUSH-IN ADAPTABLE DOVE-TAIL JOINT SEAL FOR OVEN FRONT PANEL MADE WITH HEAT AND AGE RESISTANT SILICON RUBBER, EASY TO REPLACE.
- COOKING CHAMBER IN 1 MM THICK 18/10 AISI 304 STAINLESS STEEL WITH LONG FULLY ROUNDED EDGES FOR BEST AIR FLOW AND EASIER CLEANING.
- DEFLECTOR THAT CAN BE OPENED FOR EASY FAN COMPARTMENT CLEANING.
- ADJUSTABLE HINGE FOR OPTIMAL SEAL.
- INTERNAL GLASS THAT FOLDS TO OPEN FOR EASY CLEANING.
- DOOR WITH REAR VENTILATED DOUBLE TEMPERED GLASS WITH AIR CHAMBER AND INTERIOR HEAT-REFLECTING GLASS FOR LESS HEAT RADIATION TOWARDS THE OPERATOR AND GREATER EFFICIENCY.
- PERFECTLY SMOOTH, WATERTIGHT CHAMBER.

ELECTRICAL OPERATION

- COOKING CHAMBER HEATING SYSTEM WITH ARMoured HEATING ELEMENTS IN INCOLOY 800 STAINLESS STEEL.

STEAM GENERATION - DIRECT

- DIRECT COOKING CHAMBER STEAM GENERATION SYSTEM WITH WATER INJECTION DIRECTLY ON THE FAN AND NEBULIZATION ON THE HEATING ELEMENTS. ADVANTAGE: IMMEDIATE AVAILABILITY OF STEAM IN THE COOKING CHAMBER.

STEAM GENERATION - INDIRECT (WITH STEAM GENERATOR)

- CAL-OUT SYSTEM TO PREVENT SCALE BUILD-UP WITHIN THE BOILER, AS STANDARD.
- BOILER SEMI-AUTOMATIC DE-SCALING PROGRAM.
- ALARM IN CASE OF BOILER DE-SCALING REQUIRED.
- DAILY AUTOMATIC BOILER DRAINING AND RINSING, TEMPERATURE OF DRAINED WATER BELOW 60°C.
- AUTOMATIC BOILER PRE-HEATING.
- STEAM GENERATOR HEATING ELEMENTS OF ARMoured INCOLOY 800 TYPE.
- AISI 304 FULLY INSULATED STEAM GENERATOR.

SAFETY FEATURES

- IN CASE OF A POWER FAILURE DURING WASHING, HYGIENE IS ALWAYS GUARANTEED INsofar AS THE WASHING CYCLE IS AUTOMATICALLY RESUMED.
- MAXIMUM LAST TRAY SHELF HEIGHT 160 CM USING THE MODEL'S SPECIFIC SUPPORT.
- COMPLIES WITH NATIONAL AND INTERNATIONAL STANDARDS FOR SAFE OPERATION IN CASE OF USE WITHOUT DIRECT OPERATOR SUPERVISION - IEC 60335-1 / IEC 60335-2-42.
- VENTILATED COMPONENT COOLING SYSTEM WITH ELECTRONICALLY CONTROLLED OVER-TEMPERATURE DISPLAY.
- SELF-DIAGNOSIS WITH SMART ERROR VIEWING.
- ELECTRONIC CONTROL FOR LACK OF WATER ALARM.
- DOOR OPEN/CLOSED ELECTRONIC SENSOR.
- FAN MOTOR THERMIC PROTECTION.
- COOKING COMPARTMENT SAFETY DEVICE FOR PRESSURE BUILT-UP AND DEPRESSION.
- COOKING CHAMBER TEMPERATURE LIMITER.

CLEANING AND MAINTENANCE

- EASY EXTERNAL CLEANING THANKS TO PERFECTLY SMOOTH SURFACES IN STAINLESS STEEL AND GLASS AND IPX4 PROTECTION AGAINST WATER SPLASHES.
- MANUAL CLEANING SYSTEM WITH EXTERNAL HAND SHOWER (SHOWER OPTIONAL).
- AUTOMATIC WASHING CYCLE. SEPARATE DETERGENT CONTAINER WITH AUTOMATIC DOSING.
- CALOUT DESCALING SYSTEM, THAT PREVENTS THE FORMATION AND ACCUMULATION OF LIMESCALE IN THE BOILER, WITH SEPARATE CONTAINER AND AUTOMATIC DISPENSING.
- EASY ACCESS FOR MAINTENANCE OF THE APPLIANCE FROM THE RIGHT-HAND SIDE.
- 7 AUTOMATIC WASHING PROGRAMS, WITHOUT THE NEED FOR AN OPERATOR TO BE PRESENT AFTER START-UP: MANUAL - RINSE - SOFT - ECO - HARD - HARD PLUS - GRILL.

INSTALLATION & ENVIRONMENT

- OPERATION WITHOUT ADDING THE WATER SOFTENER AND DESCALER (MODEL WITH STEAM GENERATOR).
- QUALITY ISO 9001 / SAFETY ISO 45001 / ENVIRONMENTAL ISO 14001 CERTIFICATION.
- PRODUCT RECYCLING RATE 90%.
- LCP - LIFE CYCLE PERSPECTIVE: CO2 CONSUMPTION - 380 KG CO2 EQ/YEAR. THE CALCULATION WAS PERFORMED TAKING MOD_ E101B (MODEL WITH STEAM GENERATOR), TAKING INTO ACCOUNT A HYPOTHETICAL RESTAURANT USE AND CONSIDERING 8 HOURS A DAY FOR 3.5 DAYS A WEEK, FORTY-EIGHT DAY PER YEAR.
- 100% RECYCLABLE PACKAGING.

OPERATION

- POSSIBILITY TO VIEW AND MODIFY THE RECIPE AT ANY TIME.
- RAPID COOLING WITH POSSIBLE INJECTION OF WATER INTO THE COOKING CHAMBER.
- AUTOMATIC RESUMPTION OF COOKING IN CASE OF A POWER FAILURE.
- COOL DOWN FUNCTION FOR THE RAPID FAN-COOLING OF THE COOKING CHAMBER.
- AUTOMATIC "ONE TOUCH" COOKING (AC).
- 7" COLOUR SCREEN (LCD, HIGH DEFINITION, CAPACITIVE, WITH "TOUCH SCREEN" FUNCTIONS).
- INTELLIGENT RECOGNITION OF RECIPES IN MULTILEVEL FOLDERS.
- ORGANISATION OF RECIPES INTO CATEGORIES WITH PREVIEW.
- USER INTERFACE WITH A CHOICE OF 6 LANGUAGES.
- SYNAPSY HAS 95 AVAILABLE RECIPES. EACH RECIPE HAS BEEN TESTED TO GUARANTEE BEST RESULTS.

STANDARD EQUIPMENT

- USB CONNECTION
- WI-FI CONNECTION
- AUTOMATIC CLEANING SYSTEM. SUPPLIED WITH 1 LIQUID CLEANSER TANK DL010B, 990 GR.
- SIDE RUNNERS
- MULTIPOINT CORE PROBE Ø 3 MM. FIXED PROBE
- CALOUT DESCALING SYSTEM FOR MODELS WITH BOILER. SUPPLIED WITH ANTI-SCALE PRODUCT

OPTIONAL TO BE REQUESTED WHEN ORDERING

- DSP:** DISPLAY-CONTROL PANEL PROTECTION
- SYNETH:** EXTRA CHARGE FOR ETHERNET CONNECTION
- SAFF:** QUICK CONNECTION FOR SMOKER VIA EXTERNAL CONNECTOR. SMOKER INCLUDED
- SSB091:** EXTRA CHARGE FOR REMOVABLE RACK SBE091 + COMPULSORY FRAME BTL011 - FOR CHICKEN GRILL KIT PROFESSIONAL
- NPSB:** RIGHT HINGED DOOR, EQUIPPED WITH MULTIPOINT CORE PROBE WITH EXTERNAL CONNECTOR, Ø 3 MM
- TS-NAE101B-C60:** 3-AC 400 V - 60 HZ
- TS-NAE101B-B60:** 3-AC 230 V - 60 HZ
- NPK:** CONFIGURATION FOR CONNECTION TO EXTRACTION HOOD
- SN:** EXTRA CHARGE FOR ENERGY SAVING SYSTEM CONNECTION. ELECTRIC MODELS ONLY
- APDS:** DOUBLE RELEASE DOOR OPENING
- KSCB0:** PRE-CONFIGURATION FOR QUICK CONNECTION FOR CORE PROBE VIA EXTERNAL CONNECTOR. MULTIPOINT CORE PROBE Ø 3 MM INCLUDED
- OB101E:** STEAM GENERATOR. FOR ELECTRIC MODEL
- SPP864:** EXTRA CHARGE FOR SHELF RACKS - EN (600 X 400) VERSION - BGP864
- SSB864:** EXTRA CHARGE FOR PASTRY VERSION REMOVABLE RACK SBE864 + COMPULSORY FRAME BTL011
- SSB101:** EXTRA CHARGE FOR REMOVABLE RACK SBE101 + COMPULSORY FRAME BTL011
- BGR1101:** CHICKEN GRILL KIT PROFESSIONAL - CABINET HEIGHT 670 MM
- TS-NAE101B-C50:** 3-AC 400 V - 50 HZ
- TS-NAE101B-B50:** 3-AC 230 V - 50 HZ

EXTRA ACCESSORIES THAT CAN BE INSTALLED FOLLOWING PURCHASE

- ICLD:** HAND SHOWER WITH FITTINGS AND CONNECTIONS
- KBPS101:** DOOR KIT WITH RIGHT-HAND HINGES, EQUIPPED WITH MULTIPOINT CORE PROBE WITH EXTERNAL CONNECTOR, Ø 3 MM
- CF010B:** CALFREE BOOSTED - ANTI-SCALE
- DL010B:** COMBICLEAN BOOSTED - 3 IN 1 ALKALINE CLEANSER
- DS010B:** COMBIBOILER BOOSTED - ACID DESCALER
- KNCI:** HYDRAULIC CONNECTION KIT. CONSISTING OF 2 INLET PIPES, 2 M AND Ø 50 MM DRAINAGE PIPING
- PL005:** NEBULIZER FOR CLEANSER WITH HOSE - CAPACITY 5 L.
- PL002:** NEBULIZER FOR CLEANSER - CAPACITY 2 L.
- PCSM:** FLOWMETER 10-100
- PCSF:** PURITY C STEAM 1100 CARTRIDGE
- PCSK:** PURITY C STEAM FILTER HEAD KIT
- KSA001:** NEEDLE CORE PROBE. Ø 1 MM
- KSC180:** MULTIPOINT CORE PROBE FOR LARGE ITEMS Ø 3 MM, PIN LENGTH 180 MM.
- KSC004R:** MULTIPOINT CORE PROBE Ø 3 MM.
- AFFE:** SMOKER WITH EXTERNAL POWER SUPPLY
- BSGP11:** FAT DRAIN PAN - GN 1/1 - FOR CHICKEN GRILL KIT PROFESSIONAL
- SBE091:** REMOVABLE RACK - TO BE USED WITH COMPULSORY FRAME - GN 1/1 - FOR CHICKEN GRILL KIT PROFESSIONAL
- BKC011S:** EXTRACTION HOOD WITH AIR-COOLED CONDENSER FOR STACKING KIT. FOR ELECTRIC MODELS ONLY. AVAILABLE ONLY FOR PREARRANGED OVENS. USE COLLECTOR CCE FOR EXTERNAL CONNECTION
- CCER90:** COLLECTOR FOR EXTERNAL CONNECTION, COMPLETE WITH 90° FITTING - Ø 150 MM
- NRG11:** CHICKEN GRILL KIT. CAN BE INSTALLED FOLLOWING PURCHASE
- NFX01:** FAT FILTER
- CCE:** COLLECTOR FOR EXTERNAL CONNECTION - Ø 150 MM
- SBE864:** REMOVABLE RACK - TO BE USED WITH COMPULSORY FRAME - EN (600 X 400) VERSION
- BGP864:** PAIR OF SHELF RACKS - EN (600 X 400) VERSION
- SBE101:** REMOVABLE RACK - TO BE USED WITH COMPULSORY FRAME - GN VERSION
- MCR031B:** STATIC HOLDING CABINET AND SLOW COOKING - WITH CORE PROBE
- BSC011:** CABINET IN STAINLESS STEEL WITH DOORS AND SIDE RUNNERS - 1/1 GN
- BCR011S:** HEIGHT-ADJUSTABLE TROLLEY FOR REMOVABLE OVEN RACKS WITH DRIP TRAY, AND SYSTEM FOR COUPLING / UNCOUPLING FROM OVEN COOKING CHAMBER - MIN HEIGHT 911 MM - MAX HEIGHT 1261 MM
- PLG5032:** PLUG - 380 V - 32A - 5P
- BSR011:** FLOOR STAND IN STAINLESS STEEL WITH SHELF
- BSP011:** FLOOR STAND IN STAINLESS STEEL WITH TRAY RUNNERS - 1/1 GN
- KSCBA:** PRE-CONFIGURATION FOR QUICK CONNECTION FOR CORE PROBE VIA EXTERNAL CONNECTOR - PROBE NOT INCLUDED. INSTALLATION BY AUTHORISED TECHNICIAN
- BPP101:** REMOVABLE PLATE RACKS - TO BE USED WITH COMPULSORY FRAME
- BCT101:** RACK THERMAL COVER
- SSP101:** EXTRA CHARGE FOR REMOVABLE PLATE RACKS COMPLETE WITH COMPULSORY FRAME - TO BE REQUESTED WHEN ORDERING OVEN
- BTL011:** COMPULSORY FRAME FOR REMOVABLE OVEN RACK AND PLATE RACKS
- BKC011F:** FLAT EXTRACTION HOOD WITH AIR COOLED CONDENSER. ELECTRIC MODELS ONLY. AVAILABLE ONLY FOR PREARRANGED OVENS - USE COLLECTOR CCER90 FOR EXTERNAL CONNECTION
- BKC011:** EXTRACTION HOOD WITH AIR-COOLED CONDENSER. ELECTRIC MODELS ONLY. AVAILABLE ONLY FOR PREARRANGED OVENS. USE COLLECTOR CCE FOR EXTERNAL CONNECTION. FOR OVENS MOD. 061/054 USE EXCLUSIVELY FLOOR STAND AND CABINETS MOD. BSA011, BSK011 BSC110, BSK064, BSC640
- BAP101:** STAINLESS STEEL HEAT SHIELD FOR THE UNIT SIDE PANEL
- BKQ101:** KIT BANQUETING - BPP101 + BCR011S + BCT101 - BTL011 NOT INCLUDED
- SUPMCR031B:** MODULARITY FLOOR STAND BSR011 / HOLDING CABINET MCR031B
- BRP04:** CASTOR KIT FOR FLOOR STANDS AND CABINETS, 2 WITH BRAKE - NOT COMPATIBLE WITH THE USE OF REMOVABLE RACKS - HEIGHT INCREASE + 83 MM. FOR BSR - BSC - BSK - BSP MODELS
- KTS011:** DOORS AND REAR SIDE WALLS-KIT TO TRANSFORM STAND MODEL BSP011 INTO MODEL BSC011
- SKE011P:** STACKING KIT
- BKG011P:** STACKING KIT
- SKG011P:** STACKING KIT

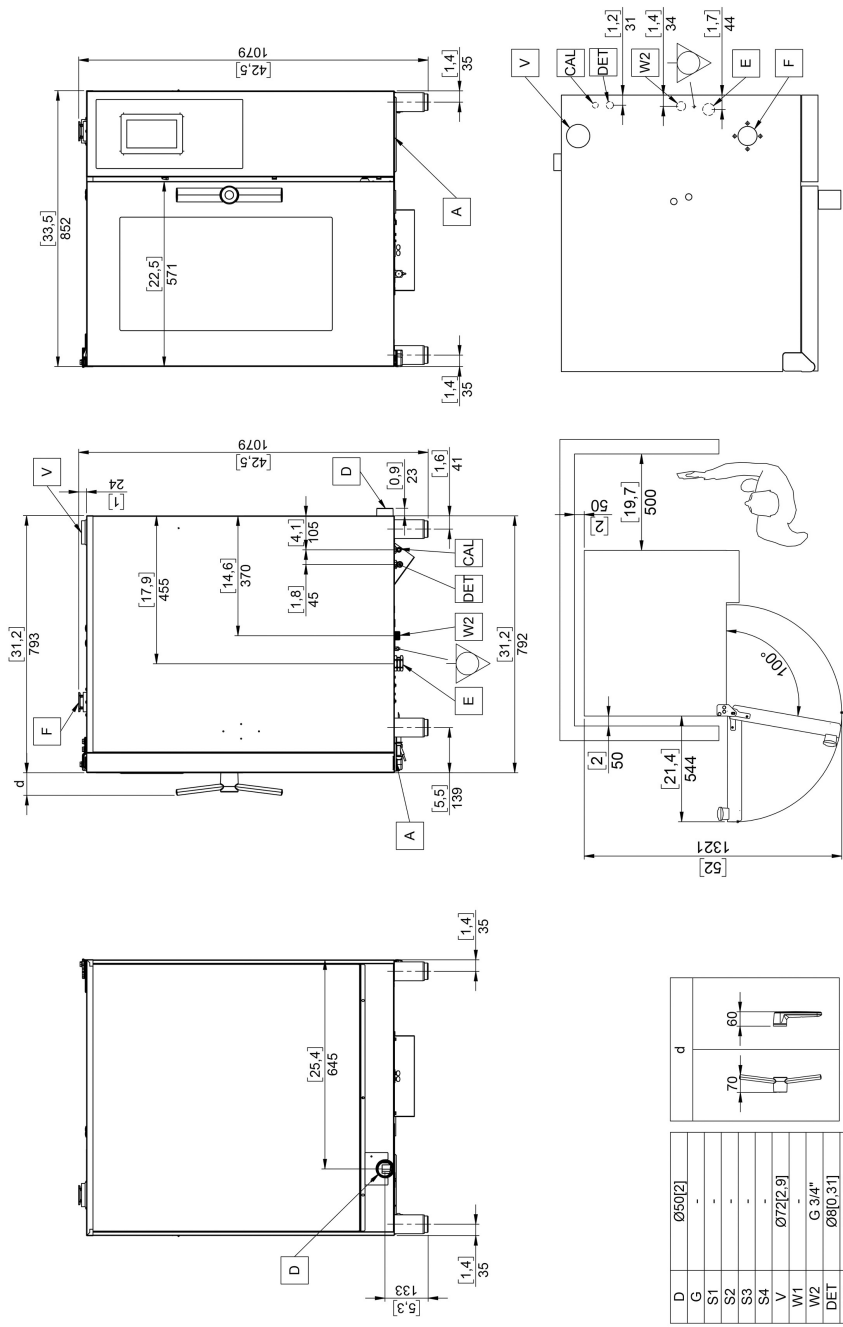

D	Ø50[2]
G	-
S1	-
S2	-
S3	-
S4	-
W1	Ø72[2,9]
W2	G 3/4"
DET	Ø8[0,31]
CAL	Ø6[0,23]

Dimensions: Millimeters [inches]

A	Technical compartment cooling air intake	D	Liquid discharge	E	Electric power supply cable inlet	F	Cooking chamber air intake
G	Gas inlet	S1	Cooking chamber fumes exhaust	S2	Cooking chamber fumes exhaust	S3*	Steam generator fumes exhaust
S4*	Steam generator fumes exhaust	V	Steam vent and cooking chamber pressure drop safety device	W1	Water inlet	W2	Softened water inlet
⚠	Equipotential connection	DET	Detergent	CAL	Descaler		

The data reported in this document is to be considered non-binding. The company reserves the right to make changes at any time, without prior notice