



EASY TOUCH 2

User friendly and totally programmable 7" ET2 USB Connection. Online platform free of charge for programming, telemetry, data analysis...thanks to the IoT Videos on display (ads, instructions, etc.) 37 languages



OUTSTANDING FEATURES

Reversing drum action as standard
Stainless steel drum as standard
Frequency inverter as standard



EFFICIENCY

CARE DRY - Intelligent humidity control. With new drum inlet temperature control.
AIR RE-CYCLE - Efficient air recirculation system
INSULATED PANELS - Complete air-flow circuit
Double door glass
OPTIMAL FLOW - New optimized system of mixed airflow
Big fluff filter



VERSATILITY

Make to order - customisation
WET CLEANING



CONNECTIVITY

Standard Danube Online IoT communication
Remote technical service
Management of laundries:



ERGONOMICS

Drawer as fluff filter, stainless steel mesh
Biggest door diameters
Opening sense of door adjustable on site



MAINTENANCE

Hinged control panel: easy and ergonomic access
Technical menu: statistics for technicians and maintenance with external console (with console option)



OTHERS

Grey skinplate outer casing, stainless steel look
Transmission by direct drive
SPRINKLER - Integrated Fire Extinguishing System
SOFT DRY - new drum with stamped holes
COOL DOWN - anti-wrinkle at the end of the cycle
Electric, gas and steam heating
CE approved



OPTIONS

- Opposite door opening
- Tropicalized model
- Dosing/spraying system
- Back panel external air + filter
- Fluff filter with grid 0,6mm (standard is 0,3mm)
- Fluff filter with grid 1,2mm (standard is 0,3mm)
- Stainless steel front and side panels
- Front panel in stainless steel
- Steam battery in stainless steel
- Low pressure steam battery
- Reduced power (12kw instead of 18kw) for DD-18
- Ship voltage for electric models: 440V III 50/60 Hz No neutral
- Other voltages available
- Maritime wooden packing

TECHNICAL DATA	UNIT.	DD-18 GOLD ET2		DD-22 GOLD ET2	
CAPACITY					
Capacity 1/18 // Capacity 1/20	Kg	18,3 // 16,5		24,3 // 21,9	
Hourly Output (electr. // gas)	Kg/h	30 // 33,6		40 // 44,6	
Evaporation capacity (electr. // gas)	l/h	14,9 // 16,3		20 // 22,3	
DRUM					
Ø Drum	mm	750		835	
Ø Door	mm	574		574	
Door center height	mm	976		1030	
Load hole bottom height	mm	689		743	
Drum length	mm	746		800	
Drum volume	l	330		438	
POWER					
Drum motor power	kW	0,37		0,37	
Fan motor power	kW	0,55		0,75	
Electric heating power	kW	18		24	
Total electric power (elec.model)	kW	18,97		25,17	
Gas heating power	kW	20,51		31	
Instant propane gas consumption (G31)	kg/h	1,76		2,66	
Instant natural gas consumption (G20)	m3/h	2,17		3,28	
Total electric power (gas model)	kW	0,97		1,17	
Steam heating power	kW	30		49,2	
Total electric power (steam model)	kW	0,97		1,17	
CONNECTIONS					
		ELECTRICAL		GAS/STEAM	
Tension 230V - I + N + T	N° x mm2 / A	-		3 x 1,5 / 20A	
Tension 230V - III + T	N° x mm2 / A	4 x 16 / 63A		3 x 1,5 / 20A	
Tension 400V - III + N + T	N° x mm2 / A	5 x 10 / 32A		3 x 1,5 / 20A	
Ø Gas inlet	BSP	1/2"		1/2"	
DIMENSIONS / PACKING DIMENSIONS					
Net width / Gross width	mm	785 / 865		890 / 970	
Net Depth / Gross Depth	mm	1125 / 1210		1255 / 1345	
Net Height / Gross Height	mm	1694 / 1840		1812 / 1940	
Net weight / Gross weight	Kg	187 / 200		210 / 230	
OTHERS					
Max airflow	m3/h	1200		1.500	
Ø Fume exhaust	mm	200		200	
Sound level	dB	64		65	

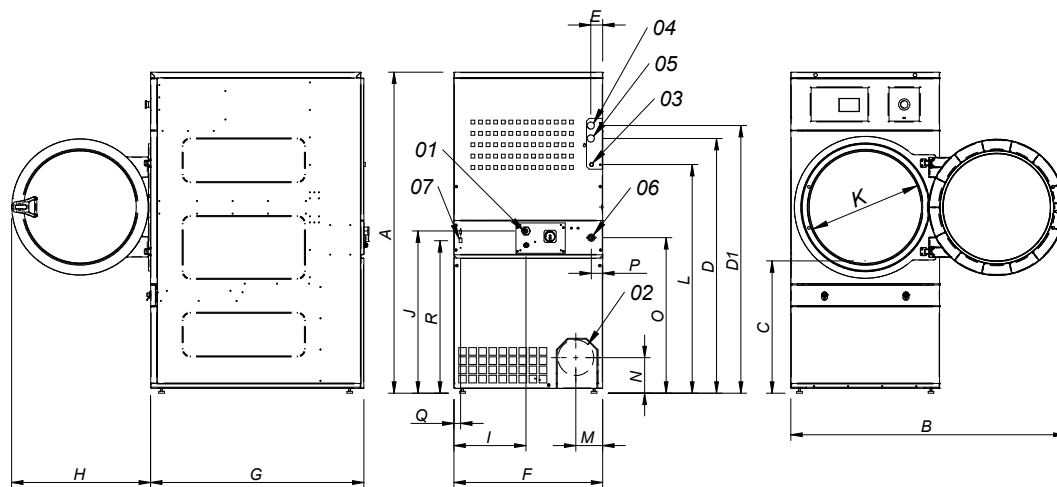

- 01 POWER SUPPLY
- 02 FUMES OUTPUT Ø200
- 03 GAS INLET 1/2"
- 04 STEAM INLET 3/4"
- 04 STEAM INLET 1" (22kg)
- 05 CONDENSATE OUTLET 3/4"
- 05 CONDENSATE OUTLET 1" (22kg)
- 06 SPRINKLER VALVE 3/4"
- 07 ETHERNET CONNECTION

	A	B	C	D	D1	E	E1	F	G	H	I	J	K	L	M	N	O	P	Q	R
DD-18	1694*	1447	689	1354	1422	68	68	785	1125	735	380	870	575	1226	133	180	830	65	35	805
DD-22	1812*	1552	743	1430	1532	112	55	890	1255	735	107	920	575	1344	238	180	885	65	37	860

* Measurement with legs mounted (30mm)

